



MicroComm DXL

DXL System Data Sheet

Description

The MicroComm DXL digital intercom system is designed to be cost effective for applications with widely distributed architectures and those of a smaller scale. It is also ideally suited for adding functionality and flexibility when retrofitting relay switched intercom systems. A comprehensive feature set gives the MicroComm DXL the power to handle projects with the most demanding requirements, and like all MicroComm family members, it incorporates digital audio technology and provides a high performance, rugged, and reliable communication solution.

Two basic building blocks form the backbone of the system. Digital Communication Controllers (DCC) are the master component of each exchange and can be interconnected to form larger systems. They incorporate the exchange processor, control software, configuration data, and network ports as well as the intercom station, master station, and audio interface boards. Digital Communication Expanders (DCE) and Talk Back Expanders (TBE) are used to increase the capacity of each exchange. Up to four DCE and/or TBE expander units can be connected to each DCC controller.

The MicroComm DXL is compatible with the same set of intercom stations, master stations, and call devices as the rest of the MicroComm family. The wide and growing variety of standard stations and specialty stations is therefore available for your use, regardless of which MicroComm system you choose.

A key feature of the MicroComm DXL is the DXL Administrator Software. This Windows Explorer style user interface runs on a standard PC and provides system configuration, logging, and diagnostic functions. With its easy to follow tree structure, simple to understand data entry dialogs, copy and paste device creation feature, and built-in device libraries, a MicroComm DXL is easy and quick to program.

FEATURES

System Architecture

- Simple, modular system architecture
- Digital audio trunks and signal processing
- Each exchange can function independently
- Exchanges can be networked to form large systems
- Unrestricted communications within each exchange
- Twenty-six channel audio trunk interconnects exchanges
- Supports MicroComm family master stations
- Full touch screen and graphic panel master control
- Telephone sets provide administrative master functions
- Supports MicroComm family intercom stations
- Supports generic 25 volt intercom stations
- Supports MicroComm Discrete Input/Output modules
- 64 x 128 pixel graphics display



- Eleven button keypad with menu driven interface
- Built-in monitoring and self-test routines

Operating Features

- Paging and program distribution to audio outputs and stations
- Audio Level Alarm threshold detection
- Sequential and group audio listen-in monitoring
- Hands free and press-to-talk operator control
- Multiple priority levels for each category
- Individual audio control for each channel
- Master groups for parallel operator control
- Six program distribution channels in each exchange
- Six system wide program distribution channels
- Flexible operational tone signaling
- Time clock and event controlled tone signaling
- Tones and messages recorded as WAV audio files
- Master station and visiting booth call recording
- Unit unmanned and time out call forwarding
- Call and program switch enabling/disabling
- Flexible display master menu architecture
- CCTV switcher and visiting booth support

DXL Administrator Software Features

- Windows Explorer style configuration

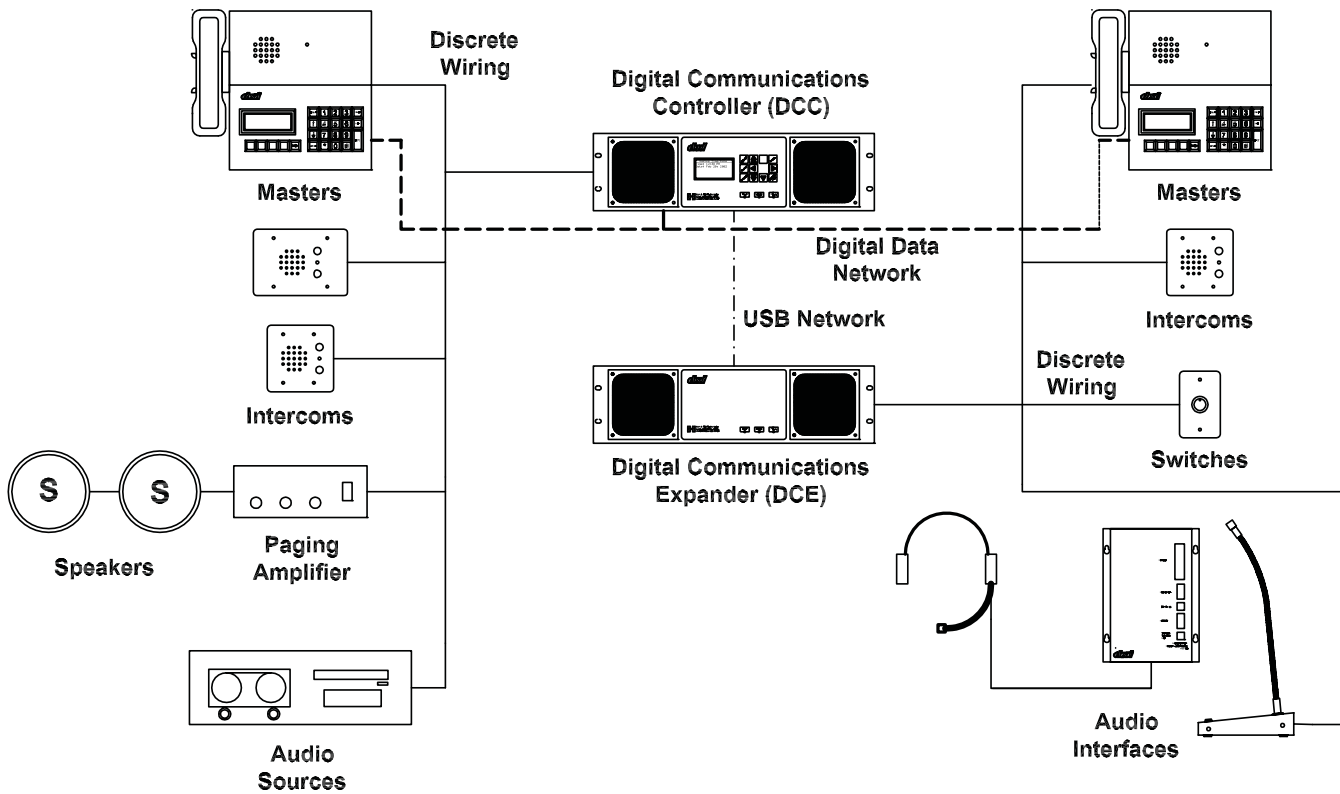

DXL Exchange

- Operates on standard PC or laptop computer
- Loads and validates configuration files
- Functions both on-line and off-line
- Provides configuration, logging, and diagnostics
- Devices displayed in both tabular and window formats
- Device library included for standard devices
- Add new devices with copy and paste commands
- Remote system access available via modem
- Manages the entire system through a single port
- Manages system security features

Identification Numbers (up to 5 digits)	99999
DCC/DCE Capacity	
Intercom Stations (half duplex)	32
Master Stations	2
Audio line inputs	2
Audio line outputs	2
Exchange Capacity	
Intercom Stations (half duplex)	160
Master Stations	10
Audio line inputs	10
Audio line outputs	10
System Capacity	
Exchanges	32
Intercom Stations (half duplex)	5120
Audio Line Inputs	320
Audio Line Outputs	320

Specifications

General	
Audio band width	300-3,500 Hz
Audio Signal Processing	Digital
Audio Switching System	Digital Time Space Switching
Control Network	Ethernet and USB
I/O Network	LonWorks

Document # DS-DXL-SYS-1.8 • Copyright © 2004 Harding Instrument Co. Ltd. • All Specifications subject to change without notice • Printed in Canada



9564 Yellowhead Trail NW Tel 780.462.7100
Edmonton, AB T5G 0W4 Fax 780.450.8396
sales@harding.ca www.harding.ca



Represented by: